

RE: Installation Instructions for BBTC1 and BBTC2 Backboxes

Important Note:

Mystery Electronics backboxes are UL listed and conform to all applicable N.E.M.A. Standards. While locally available boxes may seem acceptable as substitutes, there are differences in certain critical dimensions. For a fast and easy installation and to avoid costly onsite rework, the user is strongly cautioned to use only Mystery Electronics backboxes. They are proven to be the lowest cost alternative.

Dimensions: *nominal in inches*

	A	B	C
BBTC1	6	4	4
BBTC2	10½	4	4

Knockout patterns:

Trade size - patterns same on opposite sides.

Two sides:

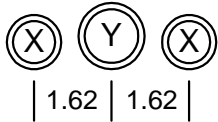

Two sides:

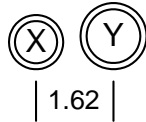

X = ½ & ¾" **Y** = ¾ & 1"

Fig.1

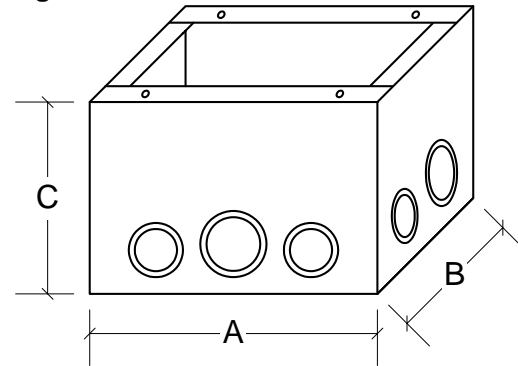

Notes:

- 1) Backbox shall be mounted such that cover of box shall be not less than 1/2" or not more than 1" below finished floor to allow proper depth to mount appropriate TC series floor box.
- 2) On projects where fork lifts and other heavy equipment are present during construction, cover the backbox with adequate material (steel plate or equal) affording maximum protection as required.
- 3) Backboxes installed in floating floors require special consideration – contact factory for details.

Wooden construction - see Fig.2

As floor box may be subjected to long-term traffic and occasional heavy loads, it is strongly recommend that firm attachment of the backbox to the framing be made with four (4) each #8 or larger screws fastened on at least two (2) planes (sides), minimum. Nails will not offer long term installation integrity as they work loose over a very short time period. Additional blocking or framing may be required to provide solid attachment of the backbox as per Notes & details herein.

When placement adjacent to structural framing is not possible, blocking must be placed at the sides of the hole that is cut for the backbox. Blocking of 1" x 2" minimum must be screw attached to the floor decking on each side of the hole. Blocking should be a few inches longer than the dimension of the hole on the two sides that are parallel to the hinge of the TC unit. Feed each strip down into the cutout hole and pull it up against the underside of the floor. Place #8 or larger flat head wood screws on 3" centers thru the floor 1" back from edge of hole along each side into the blocking. Secure backbox to blocking as above. When TC unit is installed, the floor will be clamped securely between the TC cover and the blocking strip.

Fig.2: Wood Floor

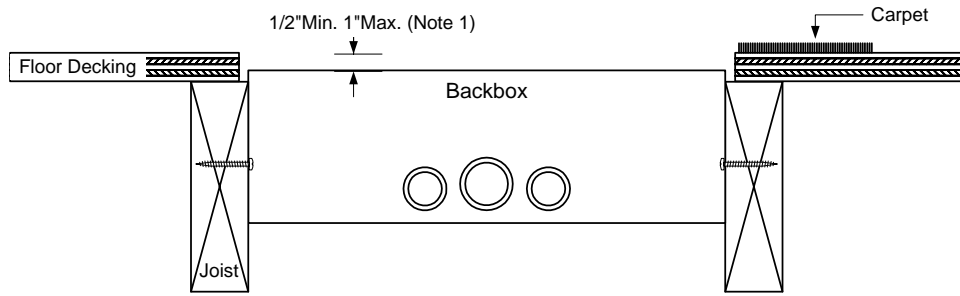

Concrete construction - see Fig.3

The Mystery Electronics TC Series are not recommended for unprotected outdoor or indoor wet, damp or severe weather locations. Certain local building codes may require that the backbox be coated with pitch for below ground applications. This can be done by spraying the outer surface of the box with automotive undercoating material available in spray cans from most auto parts or discount department stores (Wal-Mart, etc.). It is additionally advised that the contractor close all open cracks with packaging tape, duct tape, or similar to prevent concrete slurry from seeping into backbox during the concrete pour.

To automatically adjust for proper backbox depth before concrete is poured; attach a piece of 1/2" plywood of the same dimension as the backbox to the top of the box with screws. Screed concrete flush to the top of the plywood. This will result in the box being at the proper depth of 1/2" below the finished concrete surface as per Notes & details herein. Adjust depth accordingly when composite floor structures and materials are built over concrete.

Fig.3: Concrete Floor

